



**H1058S/HH1158S/HH1358S
& HV1658S
HYDRAPAK INSTRUCTIONS**

REIMANN & GEORGER CORPORATION
HOISTING PRODUCTS
P/N 6102026

BUFFALO, NY
7/22/15

TABLE OF CONTENTS

| CHAPTER | TITLE | PAGE |
|----------|--|-----------|
| 1 | SAFETY | 1 |
| 1.1 | Introduction | 1 |
| 1.2 | Safety Definitions | 1 |
| 1.3 | HydraPak and Hoist Safety Labels | 1 |
| 1.4 | HydraPak Safety Rules | 1 |
| 2 | SPECIFICATIONS | 3 |
| 2.1 | Technical Data | 3 |
| 2.2 | Recommended Hydraulic Oil..... | 3 |
| 2.3 | Nameplate and Serial Number Tag | 4 |
| 3 | SETUP | 5 |
| 3.1 | Prior to Setup | 5 |
| 3.2 | Raising the HydraPak to the Roof Using the Optional Hand Winch | 5 |
| 3.3 | HydraPak Setup | 8 |
| 4 | OPERATION | 9 |
| 4.1 | Before Operating the HydraPak..... | 9 |
| 4.1.1 | Engine Pre-Start Checks | 9 |
| 4.1.2 | Hydraulic System Pre-Start Checks | 9 |
| 4.2 | Operating the Controls..... | 10 |
| 4.3 | Preparing HydraPak for Shutdown | 12 |
| 5 | INSPECTION AND MAINTENANCE | 13 |
| 5.1 | General Maintenance Rules | 13 |
| 5.2 | Initial Inspection | 13 |
| 5.3 | Daily Inspection..... | 13 |
| 5.4 | Engine Maintenance | 14 |
| 6 | TROUBLESHOOTING | 15 |
| 7 | PARTS LIST | 18 |

LIST OF FIGURES

| FIGURE | DESCRIPTION | PAGE |
|--------|--|------|
| 2-1 | Typical HydraPak Product Nameplate | 4 |
| 3-1 | Mounting Hand Winch on HS1000 | 6 |
| 3-2 | Mounting Hand Winch on HS2000 | 7 |
| 4-1 | HydraPak Controls | 10 |
| 7-1 | H1058S, HH1158S, HH1358S and HV1658S Assembly Drawing..... | 19 |

PRE-OPERATIVE CHECKLIST

This checklist must be checked prior to each use of the HydraPak. This checklist is to be used as a guideline in conjunction with the maintenance and inspection procedures outlined in this manual. The HydraPak and related equipment must be thoroughly inspected prior to each use by a trained person. A trained person is one who has read and thoroughly understands this instruction manual and related equipment manuals and, through training and experience, has shown knowledge regarding the safe operational procedures. If you do not have such a person in your organization, please contact Reimann & Georger Corporation or its distributors and they will assist you in providing such a "trained person." Do not permit any person who is not fully trained to operate this HydraPak or the associated hoist. It is recommended that this checklist be maintained as a permanent record.

- Discuss work plan, personal protective equipment, and each crew member's responsibility before starting to set-up. All crew members must be familiar with the use of hand signals.
- Insure OSHA compliant fall protection is in place.
- Insure the operator fence is lowered.
- Insure a competent person has determined the structural deck can support the intended loads in hoisting and material handling.
- Insure all structural members of the hoist and HydraPak are free of defects and damage that may affect their integrity.
- Insure hoisting operation will clear all power lines and obstructions.
- Insure hoisting area is secured from all unauthorized personnel.
- Insure engine oil level is full.
- Insure fluid level in hydraulic reservoir is one inch from top.
- Insure flammable storage is at least ten feet from HydraPak.
- Insure HydraPak is located in a well ventilated area.
- Insure HydraPak has been properly maintained.
- Insure hydraulic hoses are properly connected and in good condition.
- Operate hoist and HydraPak with no load to test hoisting operation and HydraPak controls.

INSPECTOR: _____ **DATE:** _____

1 SAFETY

1.1 INTRODUCTION

Your Reimann & Georger Corporation H1058S, HH1158S, HH1358S and HV1658S HydraPaks have been engineered to provide performance, long term economics and safety advantages that no other type can match. However, even a well-designed and well-built hydraulic power unit can malfunction or become hazardous in the hands of an inexperienced and/or untrained user. Therefore, read this manual and related equipment manuals thoroughly before operating your HydraPak to provide maximum safety for all operating personnel, and to get the maximum benefit from your equipment.

1.2 SAFETY DEFINITIONS

A safety message alerts you to potential hazards which could injure you or others or cause property damage. The safety messages or signal words for product safety signs are **DANGER**, **WARNING**, and **CAUTION**. Each safety message is preceded by a safety alert symbol and is defined as follows:

DANGER: Indicates an imminently hazardous situation which, if not avoided, **will** cause death or serious injury. This safety message is limited to the most extreme situations.

WARNING: Indicates potentially hazardous situation which, if not avoided, **could** result in death or serious injury.

CAUTION: Indicates a potentially hazardous situation which, if not avoided, **may** result in minor or moderate injury. It may also be used to alert against unsafe practices and property-damage-only accidents.

1.3 HYDRAPAK AND HOIST SAFETY LABELS

These labels warn you of potential hazards which could cause injury. Read them carefully. If a label comes off or becomes illegible, contact Reimann & Georger Corporation for a free replacement.

1.4 HYDRAPAK SAFETY RULES

1. Operators must be thoroughly trained before operating the HydraPak and hoist. A trained person is one who has read and thoroughly understands this instruction manual and related equipment manuals and, through training and experience, has shown knowledge regarding the safe operational procedures.
2. Prior to operating the hoist with the HydraPak, there must be a plan of action outlining the work to be accomplished, individual responsibilities, personal protective equipment, and method of communication.
3. A good line of communication must be maintained between the hoist operator and the ground crew. All crew members must be familiar with hand signals.
4. Follow the Pre-Operative Checklist before using the equipment.
5. Do not use the HydraPak if it shows any signs of damage.
6. Never use the HydraPak in an explosive atmosphere and/or near combustible material that could be ignited by a spark.
7. All personnel shall be protected by OSHA compliant fall protection.
8. Hoist operator must stand behind the operator fence while the hoist is operating.
9. Hoisting area is to be clear of power lines. Consult power company before you work near power lines.
10. Hoisting area is to be kept clear of unauthorized personnel at all times. Place barricades or secure the area in such a manner that if there were an equipment failure, no personnel would be injured.

11. Keep out from under a raised load.
12. Never hoist over an open doorway.
13. Never exceed the Rated Load Capacity: 1000 lbs. on the HS1000 or 1000 lbs. for single line pull and 2000 lbs. for double line pull on the HS2000. The Rated Load Capacity is the maximum load that should ever be applied to the hoist. Rated Load Capacity is for straight line pull; avoid side loads.
14. Avoid sudden stops and shock loads.
15. Secure load before lifting.
16. Tag lines shall be used to control all loads.
17. No person shall be allowed to ride on the hoist.
18. Check the hoist and HydraPak periodically during operation. Know how to stop the HydraPak quickly in case of emergency.
19. Operate the Hydrapak in a well ventilated area.
20. Allow engine to cool ten minutes before refueling.
21. Use an approved fuel container in a well ventilated area when refueling. Move fuel container at least ten feet from fueling point before starting.
22. Never disconnect hydraulic hoses or fittings while the HydraPak is running.
23. Do not try to adjust the HydraPak while it is running.
24. Keep all body parts clear of moving parts.
25. Always shut off the HydraPak before performing any maintenance or when not using the equipment. Never remove fittings or components when hydraulic fluid is hot.
26. At end of operation, secure the hoist and HydraPak to prevent unauthorized use. Never assume you will find the equipment in the same condition in which you left it.
27. Only trained personnel are authorized to do repairs.
28. Do not operate hoist or HydraPak when under the influence of drugs, alcohol, or medication.

2 SPECIFICATIONS

2.1 TECHNICAL DATA

The following specifications apply to the H1058S, HH1158S, HH1358S and HV1658S HydraPaks. Detailed specifications for the HS1000/ HS2000 hoists are in their respective manuals.

| Model No.: | H1058S | HH1158S | HH1358S | HV1658S |
|------------------------------|--|-------------|------------|----------------|
| Engine | 10 hp Briggs | 11 hp Honda | 13hp Honda | 16 hp Vanguard |
| Number of cylinders | 1 | 1 | 1 | 2 |
| Engine Oil | 10W-30 @ < 40 deg F or 30W @ > 40 deg F | | | |
| Fuel Capacity | 4 qt. | 7 qt. | 7 qt. | 9 qt. |
| Fuel Consumption | 0.7 gph | 0.7 gph | 0.8 gph | 0.9 gph |
| Weight: | 195 lbs. | 195 lbs. | 240 lbs. | 280 lbs. |
| Hydraulic System: | | | | |
| Operating Pressure (maximum) | 2000 psi | 2000 psi | 2250 psi | 2500 psi |
| Reservoir | 6 U.S. gallons—shipping cap and vented fill cap provided | | | |
| Pump Type | Positive Displacement Gear | | | |
| Flow Setting | 5 GPM or 8 GPM | | | |
| Boom Control Valve | tandem center (T-4) | | | |
| Winch Control Valve | open center (O-4) | | | |
| Filters | Parker 921999, Fram P1653A, or AC PF16 (10 micron) | | | |
| Suction Screen | 10 mesh | | | |
| Filler/Breather | 100 mesh | | | |
| Tires: | | | | |
| Size | 4.80 x 8 | | | |
| Inflation | 30 psi | | | |
| Axle | 5/8" diameter | | | |

2.2 RECOMMENDED HYDRAULIC OIL

Many types of compatible hydraulic oil are available through your local dealer/distributor. As an original equipment manufacturer, RGC uses a Grade ISO VG 32 hydraulic turbine oil.

Extreme weather conditions or operating environments may require using a different viscosity oil or fluid type than what is provided. If you have any question concerning the type of oil suitable for H1058S, HH1158S, HH1358S or HV1658S operation, please consult your local supplier or Reimann & Georger Corporation for details.

2.3 NAMEPLATE AND SERIAL NUMBER TAG

It is important to identify your HydraPak completely and accurately whenever ordering spare parts or requesting assistance in service. The HydraPak has a product nameplate that shows the model and serial numbers, and flow and pressure ratings as shown in Figure 2-1. Record the model and serial numbers, and flow and pressure ratings for future reference.

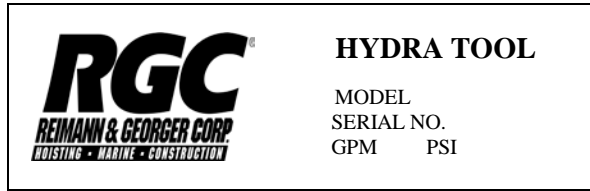

Figure 2-1.
Typical HydraPak Product Nameplate

MODEL _____

SERIAL NUMBER _____

FLOW RATING (GPM) _____ 5/8 _____

PRESSURE RATING (PSI) _____

3 SETUP

3.1 PRIOR TO SETUP

1. Insure that the HS1000/ HS2000 has been properly set up as detailed in its respective instruction manual.
2. Use a hoist beam, swing beam, or freight elevator to raise the HydraPak to the roof deck where the hoisting operations will be done. If a freight elevator or other transporting medium is not available to raise the HydraPak to the roof, it may be done using the hand winch as described in Section 3.2.



WARNING:

ENSURE ALL STRUCTURAL MEMBERS OF THE HOIST ARE FREE OF DEFECTS AND DAMAGE THAT MAY AFFECT THE INTEGRITY OF THE UNIT.



WARNING:

A COMPETENT PERSON MUST DETERMINE THAT THE STRUCTURAL DECK CAN SUPPORT THE INTENDED LOADS IN HOISTING AND MATERIAL HANDLING IN ADDITION TO THE WEIGHT OF THE COUNTERWEIGHT ON THE ROOF DECK. FAILURE TO DO THIS CAN RESULT IN DEATH, SERIOUS PERSONAL INJURY OR EQUIPMENT FAILURE.



WARNING:

ENSURE THE HOISTING AREA IS SECURED FROM ALL UNAUTHORIZED PERSONNEL. ENSURE THAT OSHA COMPLIANT FALL PROTECTION IS IN PLACE.



WARNING:

PRIOR TO SETTING UP THE HYDRAPAK, THERE MUST BE A PLAN OF ACTION OUTLINING THE WORK TO BE ACCOMPLISHED, INDIVIDUAL RESPONSIBILITIES, PERSONAL PROTECTIVE EQUIPMENT, AND THE METHOD OF COMMUNICATION. FAILURE TO DO THIS CAN RESULT IN DEATH, SERIOUS PERSONAL INJURY OR EQUIPMENT FAILURE.

3.2 RAISING THE HYDRAPAK TO THE ROOF USING THE OPTIONAL HAND WINCH



WARNING:

THE HAND WINCH IS NOT A MATERIAL HOIST. USE ONLY FOR RAISING AND LOWERING THE HYDRAPAK. DO NOT HOIST CONSTRUCTION OR DEMOLITION MATERIAL.

1. Before raising the HydraPak to the roof, check the following:
 - a. The hoist should be fully assembled except for the winch and cylinder. If the cylinder is installed, remove it because the boom will be locked in position.
 - b. Ensure that either 20 ballast blocks (1000 lbs.) for the HS1000 hoist or 40 ballast blocks (2000 lbs.) for the HS2000 hoist are secured in the counterweight basket.



WARNING:

WHEN RAISING THE POWER UNIT, TWENTY (20) BALLAST BLOCKS (1000 LBS) FOR THE HS1000 HOIST OR FORTY (40) BALLAST BLOCKS (2000 LBS) FOR THE HS2000 HOIST MUST BE SECURED IN THE LOWER COUNTERWEIGHT BASKET. FAILURE TO DO THIS CAN CAUSE DEATH, SERIOUS PERSONAL INJURY AND/OR EQUIPMENT DAMAGE.

- c. Install a tether line to the boom for swinging it over the rooftop to unload the HydraPak.
2. Mount the hand winch on the hoist so the crank is located on the right-hand side.
 - a. If using the HS1000 hoist, the winch is located on the upper counterweight leg such that the space between the front of the mounting plate and the angle clip fits over the counterweight leg cross-brace. Secure the winch in place by clamping the mounting plate to the counterweight leg with the angle clamp. See Figure 3-1.

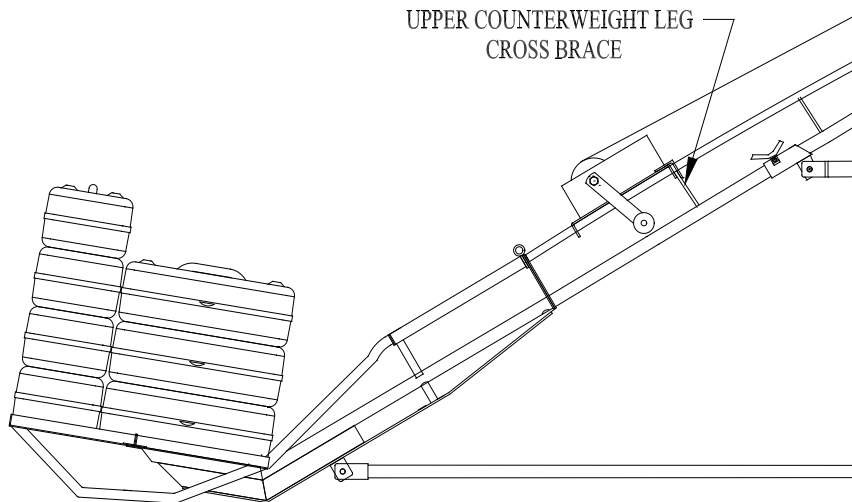

**Figure 3-1.
Mounting Hand Winch on HS1000**

- b. If using the HS2000 hoist, locate the winch on the lower counterweight leg by sliding the front lip of the winch mounting plate under the frame of upper/lower counterweight leg joint. Align the mounting holes and secure with the provided hardware. See Figure 3-2.

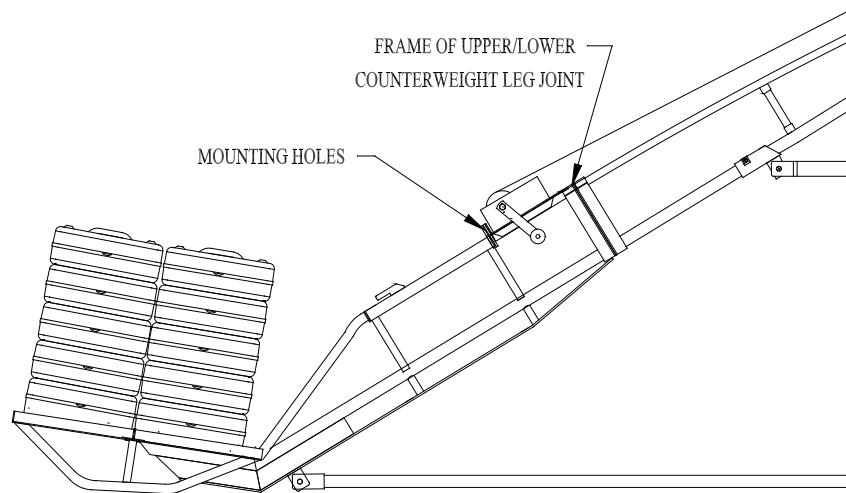

Figure 3-2.
Mounting Hand Winch on HS2000

- 3. Before reeving the wire rope, rotate the boom in over the deck and tie securely to the counterweight leg. Using a step ladder with OSHA compliant fall protection, reeve the wire rope through the pivot sheave and then between the cable keeper and the boom sheave. Always wear heavy leather glove when handling wire rope.
- 4. Inspect the wire rope for signs of wear and damage. Replace defective wire rope immediately.



WARNING:

NEVER CLIMB THE HOIST FRAME TO REEVE THE CABLE. USE A STEP LADDER (NOT AN EXTENSION LADDER) WITH OSHA COMPLIANT FALL PROTECTION.

- 5. Connect the wire rope to the lifting eye on the HydraPak. Insure the hook fastens securely to the lifting eye.
- 6. Attach a tag line to the HydraPak frame to control swaying during the raising of the power unit.
- 7. The operator on the roof cranks the winch to raise the HydraPak.



WARNING:

ALWAYS STAND CLEAR OF THE SUSPENDED UNIT.

- 8. Use the boom tether to swing the HydraPak over to the roof top.
- 9. The roof operator lowers the HydraPak to the roof by cranking the winch in the opposite direction.

3.3 HYDRAPAK SETUP

1. Before making any hydraulic connections, inspect all hoses for leaks and risks of rupture as follows:
 - a. Inspect each hose for cuts, cracks, worn spots, bulges, chemical attack, kinks or any other damage. Never stop any detected leak with your hand.
 - b. Replace a damaged hose immediately. Never repair the hose.



WARNING:

LIQUID UNDER HIGH PRESSURE CAN PIERCE THE SKIN, CAUSING SERIOUS INJURY OR DEATH. IN CASE OF INJURY, GET IMMEDIATE MEDICAL ATTENTION.

2. Connect the 1/2" hydraulic hoses from the HydraPak to the HydraWinch. To connect, retract sleeve on the female coupling and insert male coupling. To disconnect, retract sleeve on female coupling and remove male coupling.
3. Connect the 1/4" hydraulic hoses from the HydraPak to the cylinder.
4. Use caution when handling fuel for the HydraPak. Refuel only in a well ventilated area. Make sure the gas caps on the HydraPak and fuel container are properly tightened. Move the fuel container at least 10 feet from the fueling point before starting the engine.

4 OPERATION

4.1 BEFORE OPERATING THE HYDRAPAK



WARNING:

ONLY TRAINED PERSONNEL SHALL OPERATE THIS EQUIPMENT. A TRAINED PERSON IS ONE WHO HAS READ AND THOROUGHLY UNDERSTANDS THIS INSTRUCTION MANUAL AND RELATED EQUIPMENT MANUALS AND, THROUGH TRAINING AND EXPERIENCE, HAS SHOWN KNOWLEDGE REGARDING THE SAFE OPERATIONAL PROCEDURES.



WARNING:

FOLLOW THE PRE-OPERATIVE CHECKLIST IN THE FRONT OF THIS MANUAL BEFORE OPERATING.

1. Thoroughly read your hoist, HydraWinch, and engine instruction manuals for complete safety, operating and maintenance information before operating.
2. Obey all the safety labels provided on your hoist and HydraPak. These labels warn you of potential hazards that can cause serious injury or death. If a label comes off or becomes hard to read, contact Reimann & Georger Corporation for a free replacement.
3. Hoisting area is to be kept clear of unauthorized personnel. Place barricades or secure the area in such a manner that if there were an equipment failure, no personnel would be injured.

4.1.1 Engine Pre-Start Checks

1. Check engine oil level. Follow engine manufacturer specifications on type and amount of oil to add.
2. Check the engine air cleaner and air intake screen for dirt or obstructions. Clean as required.
3. Fill the fuel tank with an approved fuel container in a well ventilated area. Move fuel container at least ten feet from HydraPak before starting.

4.1.2 Hydraulic System Pre-Start Checks

Check hydraulic reservoir as follows.

- a. Replace the shipping cap with the chrome filler/breather cap provided.
- b. Fluid level should be one inch from the top of tank.



WARNING:

ENSURE HYDRAULIC HOSES ARE PROPERLY CONNECTED AND IN GOOD CONDITION.

4.2 OPERATING THE CONTROLS



WARNING:

WHEN OPERATING THE HYDRAPAK, OBSERVE ALL SAFETY PRECAUTIONS DESCRIBED IN THE HYDRAPAK, ENGINE AND HOIST INSTRUCTION MANUALS. FAILURE TO COMPLY COULD RESULT IN DEATH, SERIOUS INJURY AND/OR EQUIPMENT DAMAGE.



WARNING:

A GOOD LINE OF COMMUNICATION MUST BE MAINTAINED BETWEEN THE HOIST OPERATOR AND THE GROUND CREW.

1. The 5/8 lever provides an output of either 5 or 8 GPM. See Figure 4-1. This selection allows the hydraulic winch to operate at two different speed ranges. Within these ranges, engine speed can be varied to further adjust hoisting speeds. Speeds vary to about 165 fpm with a single part of line. A speed of up to 80 fpm occurs when using the HS2000 with two parts of line. As wire rope is wound onto the drum, the effective drum diameter increases which increases lifting speed and decreases lifting capacity.

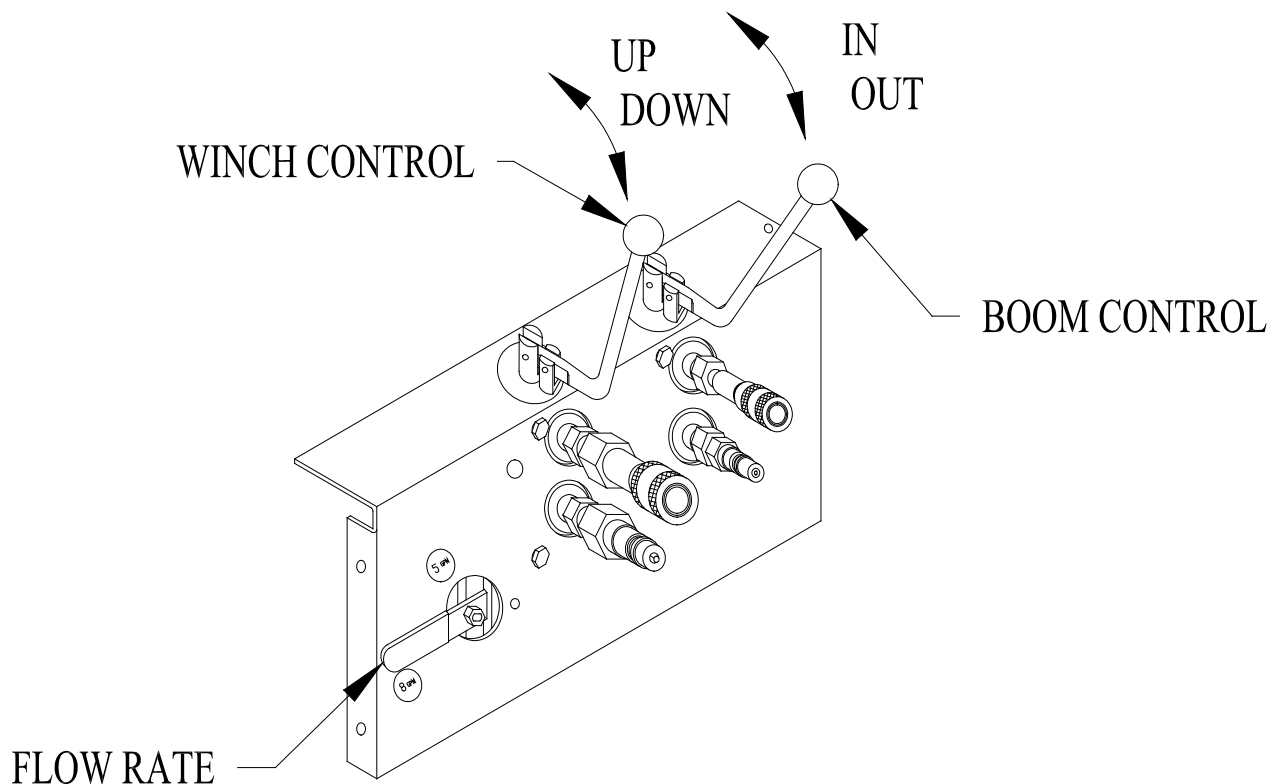

Figure 4-1.
HydraPak Controls

- a. If using an HS1000 hoist:
 - (1) The 8 GPM setting is used for light loads under 750 lbs.
 - (2) The 5 GPM setting is used for heavy loads up to 1000 lbs. If lifting speed must be further slowed, run the engine at reduced throttle.
- b. If using an HS2000 hoist:

- (1) The 8 GPM setting is used for light loads, less than 1000 lbs., with two parts of a line or 500 lbs. with a single part of a line. At the 8 GPM setting, the line speed is 165 feet per minute with a single part of line or 83 feet per minute with two parts of a line.
 - (2) The 5 GPM setting is used when lifting heavy loads (up to 2000 lbs. capacity) with two parts of a line. If lifting speed must be further slowed, run the engine at reduced throttle.
2. The hoist operator must remain behind the operator fence where hoisting and boom rotation can be done in safety and comfort. However, when handling loads at the roof edge, all personnel must be protected by OSHA compliant fall protection.



WARNING:
PERSONNEL MUST NEVER SECURE A LIFE LINE TO THE HOIST FRAME STRUCTURE.



WARNING:
FAILURE TO REMAIN BEHIND THE PROTECTIVE FENCE DURING HOIST OPERATION CAN LEAD TO SERIOUS PERSONAL INJURY OR DEATH.

3. Place the control levers in neutral. Then start the HydraPak and allow to warm up. Know how to stop your HydraPak quickly in case of emergency. Consult the engine manual for detailed operation of engine controls.
4. Put the throttle in the middle position when starting and slow when stopping the engine. This provides a warming and cooling period.
5. Pull winch control lever up to raise a load and down to lower a load. See Figure 4-1. Never allow anybody to ride on the hoist. Make a few “dry runs” (without load, but **with** ballast) to become familiar with operation, controls, and HydraPak, and to test hoisting clearance. Always maintain 10-20 pounds of wire rope tension with a cable weight. Do **NOT** attempt to make any equipment adjustments during operation.



CAUTION:
THE WINCH DRUM MUST ALWAYS HAVE AT LEAST THREE TURNS OF WIRE ROPE WHEN THE LOAD IS AT THE LOWEST POINT OF TRAVEL.

6. Before lifting, secure the load from shifting and insure the safety latch on the hook is not supporting any load. Use tag lines to control all loads. Never hoist over an open doorway.



WARNING:
AVOID SUDDEN STOPS AND SHOCK LOADS.



WARNING:
KEEP OUT FROM UNDER A RAISED LOAD.

7. Use the boom control lever shown in Figure 4-1 to swing the boom 135° to load or unload material on the roof deck where you are working.

4.3 PREPARING HYDRAPAK FOR SHUTDOWN

At the end of operation, secure the equipment to prevent unauthorized use. Never assume you will find the equipment in the same condition that you left it. Proceed as follows:

1. Swing the boom to the 135° position over rooftop. Insure that all lifting tension has been removed from the wire rope.
2. Move throttle lever to “slow” position and shut off HydraPak.



WARNING:

NEVER DISCONNECT ANY HYDRAULICALLY OPERATED PART OF THE HYDRAPAK OR HOIST OR REMOVE HYDRAULIC COMPONENTS, LINES, OR FITTINGS WHILE THE HYDRAPAK IS RUNNING OR WHENEVER THE HYDRAULIC FLUID IS HOT.

LIQUID UNDER PRESSURE CAN PIERCE THE SKIN, CAUSING SERIOUS INJURY OR DEATH. HOT LIQUID CAN CAUSE SERIOUS PERSONAL BURNS. IF AN INJURY OCCURS, GET IMMEDIATE MEDICAL ATTENTION.

5 INSPECTION AND MAINTENANCE

5.1 GENERAL MAINTENANCE RULES

Maintenance information for the associated hoist and HydraWinch is in the respective manuals specifically for these units.

1. Proper maintenance of the HydraPak and related equipment consists of adhering to all the guidelines given in this chapter and in the Pre-Operative Checklist in the front of this manual. Proper maintenance is required to maintain the system in good condition, which is defined as each part being free of damage or functional defects.
2. Review and follow all the safety rules given in Chapter 1 before attempting any maintenance.
3. Only authorized personnel should be allowed in the maintenance area. Authorized personnel are the trained people as defined below and their supervision.
4. Repairs must be made only by trained personnel. A trained person is one who has read and thoroughly understands this instruction manual and related equipment manuals and, through training and experience, has shown knowledge regarding the safe operational procedures.
5. All authorized maintenance personnel should be wearing appropriate safety equipment.



WARNING:

BEFORE DOING ANY MAINTENANCE OR REPAIRS ON THE HYDRAPAK, SHUT IT DOWN AND LOCK IT OUT TO PREVENT ACCIDENTAL STARTUP. RELIEVE OR RENDER SAFE ALL THE POTENTIALLY HAZARDOUS ENERGY.



WARNING:

NEVER DISCONNECT ANY HYDRAULICALLY OPERATED PART OF THE HYDRAPAK OR HOIST OR REMOVE HYDRAULIC COMPONENTS, LINES, OR FITTINGS WHILE THE HYDRAPAK IS RUNNING OR WHENEVER THE HYDRAULIC FLUID IS HOT.

6. Hydraulic fluid can become contaminated after extended periods of use. Check to see that the fluid is clean and change at recommended intervals to extend HydraPak's life. Refer to Section 5.4 for maintenance information.

5.2 INITIAL INSPECTION

HydraPak setup and dismantling must be done by trained personnel only as defined in Section 5.1. Each time after setting up the HydraPak and before placing it in service, all parts of it must be thoroughly inspected by trained personnel as described in the remainder of this chapter.

5.3 DAILY INSPECTION

It is important that all the maintenance procedures outlined in the Pre-Operative Checklist in the front of this manual be done daily. Details on inspecting the engine are given in Section 5.4.

All broken, worn or defective parts must be repaired or replaced before startup.

5.4 ENGINE MAINTENANCE

The engine is guaranteed against defects by its manufacturer. Follow the manufacturer's instructions for proper lubrication and maintenance. The following table summarizes the type and frequency of maintenance required. For repairs, contact the nearest authorized service center.

| TYPE OF MAINTENANCE | FREQUENCY OF SERVICE |
|--|----------------------|
| Check and clean obstruction from air intake screen | Daily |
| Check and clean obstruction from heat exchanger* | Daily |
| Check engine oil level—add if required | Daily |
| Check reservoir oil level—add if required | Daily |
| Wash air filter pre-cleaner | 25 hrs. |
| Change engine oil after first 5 hrs. | 50 hrs. |
| Check air cleaner filter—replace if necessary | 100 hrs. |
| Check and clean obstructions from cooling fins and external surfaces | 100 hrs. |
| Check battery electrolyte if used—add if necessary | 50 hrs. |
| Check, clean, and replace spark plug | 100 hrs. |
| Have cylinder head removed and cleaned (leaded fuel) | 100 hrs. |
| Have cylinder head removed and cleaned (unleaded fuel) | 200 hrs. |
| Replace reservoir filter and oil after first 50 hrs. | 250 hrs. |
| Clean suction screen in reservoir | 250 hrs. |
| Check coupling spider | 250 hrs. |
| Grease wheel bearings | 500 hrs. |
| Check ignition timing | 500 hrs. |
| Check valves and tappet clearance | 500 hrs. |
| Check fuel filter in line | 500 hrs. |
| Lightly oil throttle cable | 500 hrs. |

*The hydraulic heat exchanger must always be kept clean and free of obstructions. Check it daily before operating and frequently during use. If debris builds up on the screen during operation, remove debris as soon as it is safely possible.



CAUTION:

AN OBSTRUCTED HEAT EXCHANGER WILL CAUSE THE HYDRAULIC SYSTEM AND ENGINE OIL TO OVERHEAT AND FAIL PREMATURELY.

6 TROUBLESHOOTING

The following chart is intended to assist with troubleshooting the H1058S, HH1158S, HH1358S and HV1658S HydraPaks. While not all inclusive, the chart outlines the most common causes of a problem and the recommended course of action.

The troubleshooting guides for the associated hoist and HydraWinch are in the manuals specifically for these units.



CAUTION:

IF THE PROBLEM WITH THE ENGINE IS NOT CERTAIN, ALWAYS FOLLOW THE MANUFACTURER'S WARRANTY POLICY BEFORE ANY OTHER REPAIR OR MAINTENANCE IS ATTEMPTED.

| SYMPTOM | CAUSE AND CORRECTIVE ACTION |
|---|---|
| <p>HydraPak won't lift load—engine operating normally.</p> | <p>Low fluid level in reservoir—fill to required level.</p> <p>Flow restriction caused by:</p> <ul style="list-style-type: none"> a. Kinked or damaged hose b. Pinched or damage steel line c. Poor connection in either a hose or steel line. <p>Control valve operating in wrong direction.</p> <p>Coupling between engine and pump damaged—replace the following items as required:</p> <ul style="list-style-type: none"> a. Coupling spider worn out b. Pump or engine key sheared. <p>Pump or motor defective—contact the nearest authorized service center.</p> |
| <p>HydraPak is lifting load slowly—engine operating normally.</p> | <p>Engine speed too slow—increase throttling.</p> <p>Load not moving freely—check for block or cable malfunctions on hoist</p> <p>Too much cable on drum—hoisting capacity decreases as wire rope diameter increases.</p> <p>Single line operation being attempted for more than a 1000 pound load. Use double line operation for loads up to 2000 pounds on HS2000 hoist. Reduce load for HS1000 hoist.</p> <p>HydraPak attempting to lift more than stated capacity of hoist—check capacity rating and reduce load weight as needed.</p> <p>Low fluid level in reservoir—fill to required level.</p> |

| | |
|--|---|
| <p>HydraPak lifting load slowly—engine operating normally (continued).</p> | <p>One or more of the following flow restrictions:</p> <ol style="list-style-type: none"> a. Hose kinked or damaged b. System filter clogged—fluid going through bypass. c. Suction filter clogged—fluid going through bypass. d. Steel line pinched or damaged. e. Heat exchanger clogged. <p>Control valve not fully activated.</p> <p>Oil viscosity too heavy for cold climate—contact your local supplier or Reimann & Georger Corporation for information.</p> <p>Pump or motor damaged or worn—contact your nearest authorized service center.</p> <p>System relief valve malfunctioning:</p> <ol style="list-style-type: none"> a. Set too low for application. b. Stuck partially open c. Has broken spring. <p>Extension hoses too long:</p> <ol style="list-style-type: none"> a. Hoses over 50 feet long add sufficient friction to the hydraulic system to slow down the hoist slightly. b. Where possible, use as few quick disconnects as possible. c. An increase in system pressure may be required to compensate for long hose runs. Consult your local supplier or Reimann & Georger Corporation for information. <p>Hydraulic oil flow set too low—increase flow from 5 gpm to 8 gpm.</p> |
| <p>System overheats—engine operating normally.</p> | <p>Low fluid level in reservoir—fill to required level.</p> <p>Air intake of heat exchanger clogged/dirty.</p> <p>Severe operating conditions caused by extremely high ambient temperature and/or extended duty cycle—operate HydraPak intermittently to provide cooling periods.</p> <p>Relief valve set too low causing unnecessary bypassing of oil.</p> |
| <p>Oil is foaming.</p> | <p>Low fluid level in reservoir—fill to required level.</p> <p>Water in oil.</p> <p>Pump shaft seal worn out causing air to be drawn into pump.</p> <p>Air leak in suction line.</p> <p>Improper type of hydraulic oil—as an original equipment manufacturer, RGC uses a Grade ISO VG 32 hydraulic oil. If you have any questions concerning the type of oil you should use for your HydraPak, consult your local supplier or RGC for details.</p> |
| <p>Pump leaks.</p> | <p>Plugged reservoir filler/breather.</p> |

| | |
|-------------------------|--|
| | <p>Shipping cap installed—use chrome filler/breather cap supplied. Shaft seal worn on pump.</p> <p>Cracked inlet/outlet fitting.</p> |
| Engine frozen. | No oil in crankcase—service at engine manufacturer service center or replace engine with equivalent. |
| Engine running roughly. | Engine out of adjustment—tune engine after consulting engine manufacturer. |

7 PARTS LIST

The following parts list applies to the H1058S, HH1158S, HH1358S and HV1658S HydraPaks only. The parts list for the associated swing hoist is in the separate manual for this item. Each item number on this parts list can be matched with the item number shown on the Figure 7-1 assembly drawing.

| Item Number | Part Number | Quantity | Description |
|-------------|-------------|----------|---|
| 1 | 0545904 | 1 | MAIN FRAME |
| 2 | 2510872 | 1 | RESERVOIR |
| 3 | 6000921 | 1 | FILLER BREATHER CAP |
| 4 | 0504746 | 2 | HANDLE WITH PINS & KNOB |
| 5 | 0514414 | 2 | HANDLE W/ GRIP |
| 6 | 6000908 | 1 | SUCTION STRAINER |
| 7 | 0545906 | 2 | RESERVOIR MOUNTING BRACKET |
| 8 | 6950558 | 1 | PUMP 5/8 GPM (PARKER) |
| 9 | 6700873 | 1 | COUPLING HALF 1/2" PUMP |
| 10 | 6700907 | 1 | COUPLING INSERT |
| 11 | 6700906 | 1 | COUPLING HALF 1" ENGINE |
| 12 | 5800387 | 2 | COTTER HAIR PIN |
| 13 | 7600871 | 2 | TIRE/RIM ASSEMBLY |
| 14 | 2504743 | 1 | AXLE |
| 15 | 6900454 | 1 | PUMP BRACKET |
| 16 | 5800138 | 5 | CLEVIS PIN ROUNDED SNAP |
| 17 | 0503984 | 1 | FRONT SUPPORT LEG W/ GRIP |
| 18 | 0500432 | 1 | HEAT EXCHANGER (H1058, HH1158,& HH1358) |
| 18 | 0543432 | 1 | HEAT EXCHANGER (HV1658) |
| 19 | 5800866 | 4 | HEAT EXCHANGER MOUNT |
| 20 | 6901502 | 1 | PUMP ACCESS COVER |
| 21 | 0555041 | 1 | ENGINE 10 HP ELECTRIC/PULL |
| 21 | 2555772 | 1 | ENGINE 16 HP VANGUARD |
| 21 | 0555316 | 1 | ENGINE 11 HP HONDA |
| 21 | 0555326 | 1 | ENGINE 13 HP HONDA |
| 22 | 5044795 | 1 | VALVE (WINCH) W/HANDLE |
| 23 | 6414748 | 2 | KNOB (BALL) |
| 24 | 5044794 | 1 | VALVE (BOOM) W/HANDLE |
| 25 | 6000969 | 1 | COUPLING FEMALE 1/4" |
| 26 | 6000967 | 1 | COUPLING MALE 1/4" |
| 27 | 0524382 | 1 | CONTROL PANEL |
| 27 | 6204383 | 1 | CONTROL PANEL DECAL |
| 28 | 6004722 | 1 | FILTER HEAD |
| 29 | 6004723 | 1 | FILTER ELEMENT |
| 30 | 6000904 | 1 | FILTER ASSEMBLY |
| 31 | 5401564 | 1 | BATTERY STRAP |
| 32 | 5400861 | 1 | BATTERY |
| 33 | 6000865 | 1 | BALL VALVE |
| 34 | 6000920 | 1 | COUPLING MALE 1/2" |
| 35 | 6000919 | 1 | COUPLING FEMALE 1/2" |

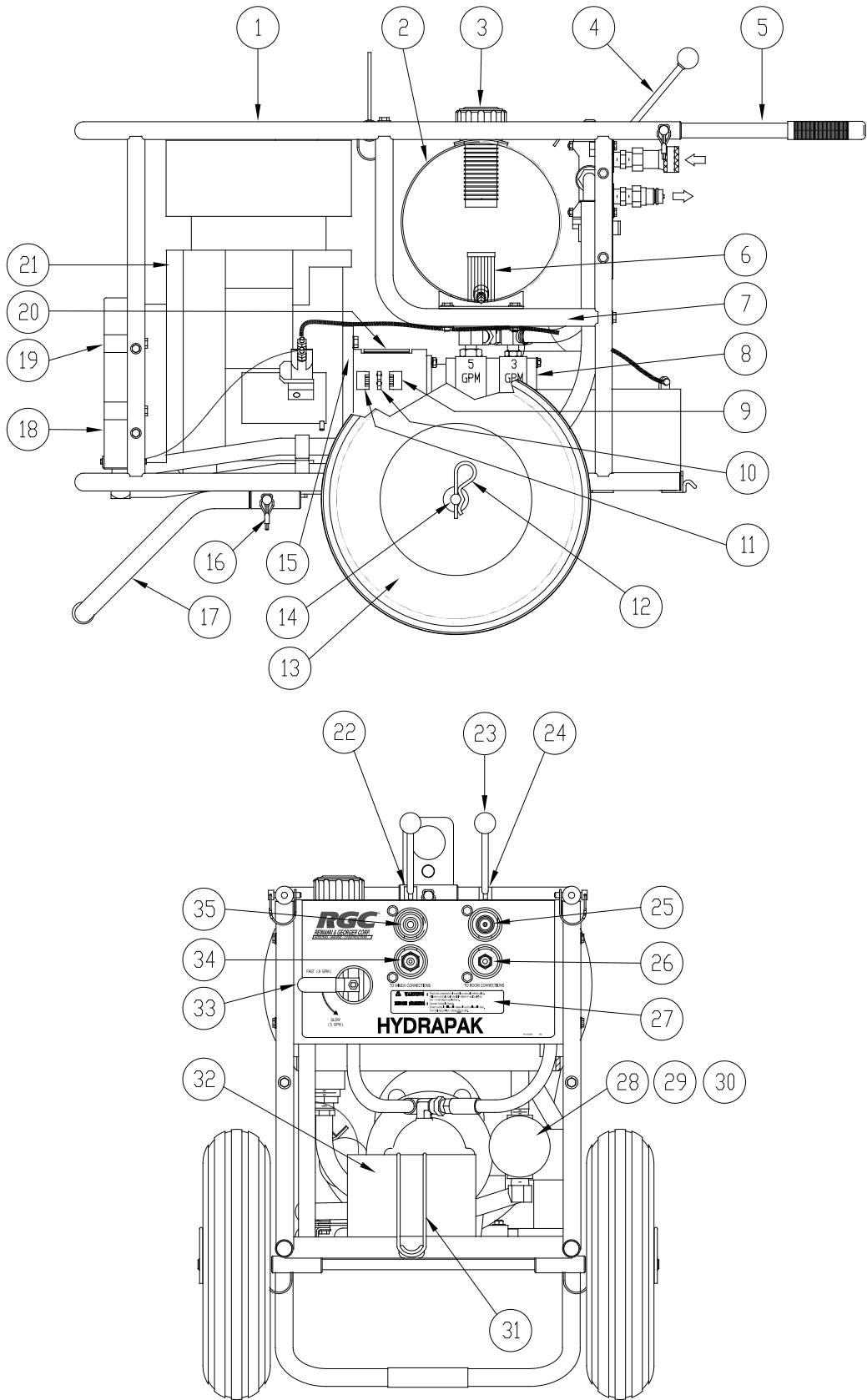

Figure 7-1.
H1058S, HH1158S, HH1358S and HV1658S Assembly Drawing

LIMITED PRODUCT WARRANTY

**Reimann & Georger Corporation
Hoisting and Construction Products**

A. LIMITED WARRANTY

Reimann & Georger Corporation (the "Manufacturer") warrants to the original purchaser (the "Buyer") that all Reimann & Georger Hoisting and Construction products shall be free of defects in material and workmanship for a period of one (1) year from date of original purchase.

B. MANUFACTURER'S OBLIGATIONS

The Manufacturer's sole obligation under this Limited Warranty is the repair or, at the Manufacturer's discretion, the replacement of parts found to be defective. Parts and equipment must have authorization from the Manufacturer prior to return to the Manufacturer or repair by an authorized service person. Costs of transportation and other expenses connected with replacing or repairing parts are not covered under this Limited Warranty.

C. PARTS MANUFACTURED BY OTHERS

This Limited Warranty does not cover any parts manufactured by others. Such parts are subject to the warranty, if any, of their respective manufacturers, and are to be repaired only by a respective authorized service person for such parts. The Manufacturer shall have no obligation to undertake repairs of parts manufactured by others.

D. NO SPECIAL, INCIDENTAL, OR CONSEQUENTIAL DAMAGES

IN NO EVENT SHALL THE MANUFACTURER BE LIABLE TO THE BUYER OR ANY OTHER PERSON FOR ANY INDIRECT, SPECIAL, INCIDENTAL OR CONSEQUENTIAL LOSSES OR DAMAGES CONNECTED WITH THE USE OF THE PRODUCT UNDER THIS LIMITED WARRANTY. SUCH DAMAGES FOR WHICH THE MANUFACTURER SHALL NOT BE RESPONSIBLE INCLUDE, BUT ARE NOT LIMITED TO, LOST TIME AND CONVENIENCE, LOSS OF USE OF THE PRODUCT, THE COST OF A PRODUCT RENTAL, COSTS OF GASOLINE, TELEPHONE, TRAVEL, OR LODGING, THE LOSS OF PERSONAL OR COMMERCIAL PROPERTY, AND THE LOSS OF REVENUE.

E. NO LIABILITY IN EXCESS OF PURCHASE PRICE

IN NO EVENT SHALL THE MANUFACTURER'S OBLIGATIONS UNDER THIS LIMITED WARRANTY EXCEED THE PURCHASE PRICE OF THE PRODUCT.

F. NO EXTENSION OF STATUTE OF LIMITATIONS

ANY REPAIRS PERFORMED UNDER THIS WARRANTY SHALL NOT IN ANY WAY EXTEND THE STATUTES OF LIMITATIONS FOR CLAIMS UNDER THIS LIMITED WARRANTY.

G. WAIVER OF OTHER WARRANTIES

THE EXPRESS WARRANTIES SET FORTH IN THIS LIMITED WARRANTY ARE IN LIEU OF AND EXCLUDE ANY AND ALL OTHER WARRANTIES, EXPRESS OR IMPLIED, INCLUDING, BUT NOT LIMITED TO, THE IMPLIED WARRANTIES OR MERCHANTABILITY AND FITNESS FOR A PARTICULAR PURPOSE.

H. PROCEDURE FOR WARRANTY PERFORMANCE

If the product fails to perform to the Manufacturer's specifications, the Buyer must provide the Manufacturer with the applicable model and serial numbers, the date of purchase, and the nature of the problem.

I. ADDITIONAL EXCLUSIONS FROM THIS LIMITED WARRANTY. THIS LIMITED WARRANTY DOES NOT COVER ANY OF THE FOLLOWING:

1. Equipment which has been abused, damaged, used beyond rated capacity, or repaired by persons other than authorized service personnel.
2. Damage caused by acts of God which include, but are not limited to, hailstorms, windstorms, tornadoes, sandstorms, lightning, floods, and earthquakes.
3. Damage under conditions caused by fire or accident, by abuse or by negligence of the user or any other person other than the Manufacturer, by improper installation, by misuse, by incorrect operation, by "normal wear and tear", by improper adjustment or alteration, by alterations not completed by authorized service personnel, or by failure of product parts from such alterations.
4. Costs of repairing damage caused by poor or improper maintenance, costs of normally scheduled maintenance, or the cost of replacing any parts unless done as the result of an authorized repair covered by the one (1) year Limited Warranty.
5. Costs of modifying the product in any way once delivered to the Buyer, even if such modifications were added as a production change on other products made after the Buyer's product was built.

J. NO AUTHORITY TO ALTER THIS LIMITED WARRANTY

No agent, representative, or distributor of the Manufacturer has any authority to alter the terms of this Limited Warranty in any way.